

PYELEC



Instrumentation and Control

BARCELONA – VALLADOLID – ZARAGOZA – PAMPLONA - VALENCIA



INDEX

1. – PURPOSE OF THE SYSTEM	3
2. – GENERAL DESCRIPTION OF THE SYSTEM	5
3. – ELECTRICAL – ELECTRONICAL COMPOSITION	6
3.1. <u>CONTROL CIRCUIT</u>	6
3.2. <u>ConNECTIONS</u>	8
4. – MECHANICAL COMPOSITION	9
1. <u>PROTECTIVE COVER</u>	9
2. <u>SUPPORTING PANEL</u>	9
3. <u>SHEET SUPPORT</u>	9
4. <u>SPRING</u>	9
5. <u>UPPER SUPPORT</u>	9
6. <u>CALYPER</u>	9
7. <u>COVER</u>	9
8. <u>BRACKET POTENTIOMETER</u>	9
9. <u>GUIDING SYSTEM</u>	9

1.- PURPOSE OF THE SYSTEM

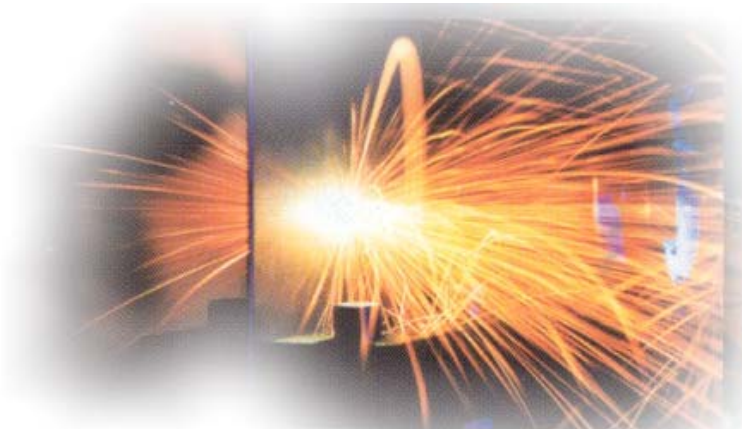

It is a system that solves certain problems inherent to the resistance welding applications by robotised handling.

In the resistance welding application a wear of the copper electrodes is produced which reduces it's useful lifespan.

This wear causes the electrodes to move each time further away from the item to be welded, causing the following effects:

- ✓ The weld force system is forced to work excessively.
- ✓ In doing so, the force on the item to be welded is increased too much, producing distortions.
- ✓ The initial and theoretic TCP (Tool Center Point) of the robot does not agree with the real TCP real, as it varies through the electrodes' wear, causing bad quality welding.
- ✓ The useful life-span of the electrodes is not optimal so a large quantity of material is wasted.

To solve these problems we have designed an automatic ON-LINE measuring system of the electrodes' wear that corrects the theoretic TCP of the robot depending on the measured value of the electrodes' wear.

There exist many applications in which this system might be applied, but it is especially designed for those with the pincers embedded on the robot, or the pincers on the floor and managed by the robot. The most important advantages are:

- ✓ Reduction of rejections by a 98%.
- ✓ Reduction by 28% of the electrodes' consumption.
- ✓ Welding quality increase.
- ✓ Increase in production time.
- ✓ Increase of useful life-span of the welding elements.
- ✓ Swift depreciation through low cost of the system.

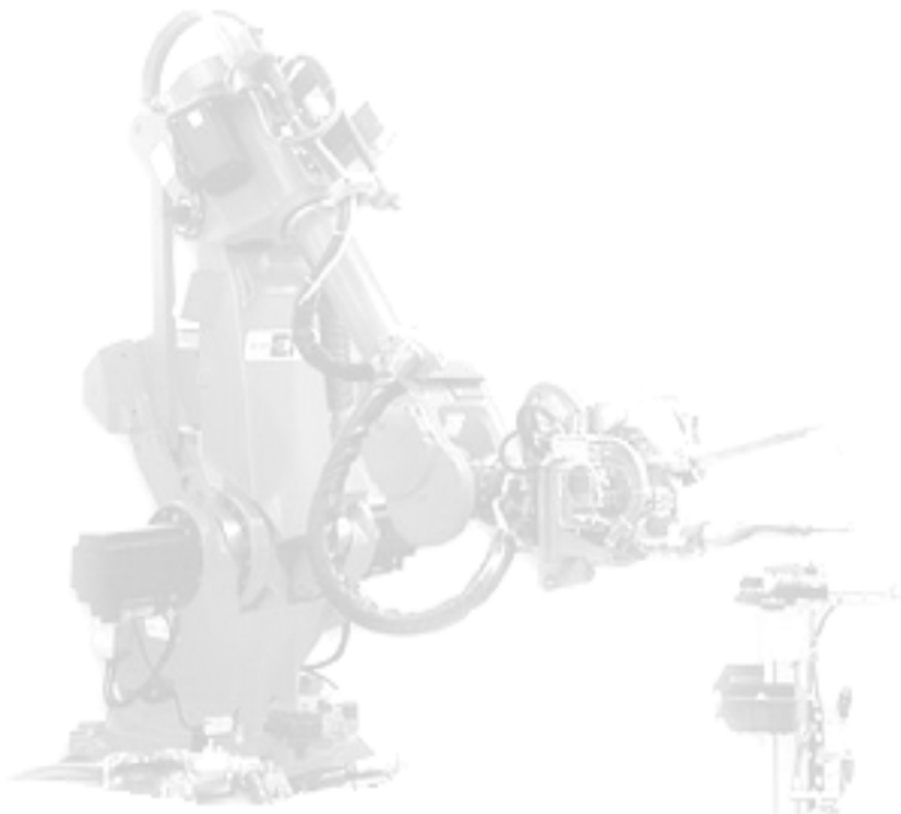

2. – GENERAL DESCRIPTION OF THE SYSTEM

The most important mission of this system is to adjust automatically the robot's trajectories depending on the measured value of the electrodes' wear, in such a way that the distance between the electrodes and the item to be welded is a constant one.

The system consists of two well defined units:

- **Physical measuring system:** In charge of transforming the measured value into an analog signal through the calyper system.
- **Translating system:** Converts the analog signal from the calyper into a digital one and translates it for handling by the robot.

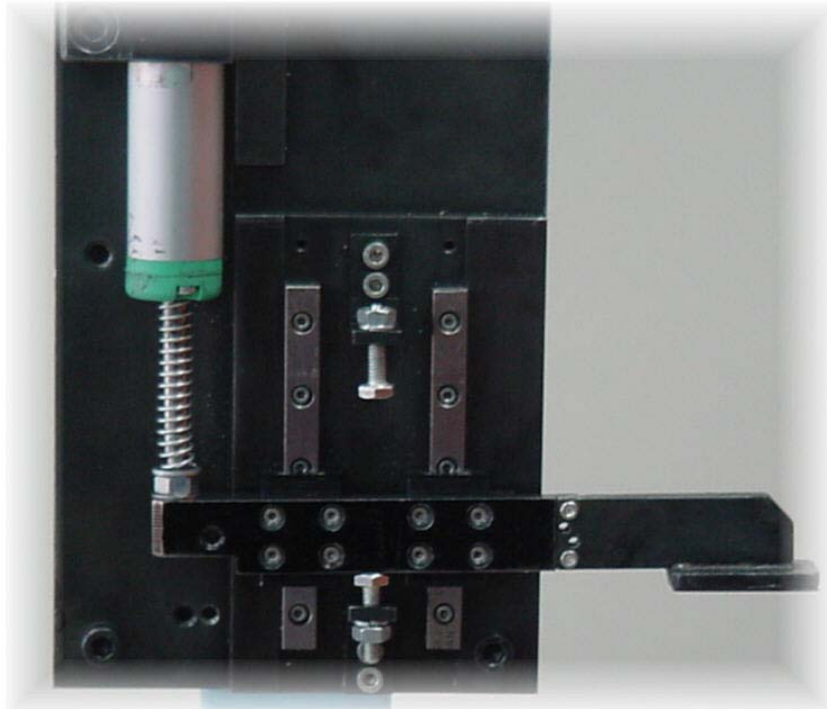

3. – ELECTRICAL – ELECTRONICAL COMPOSITION

Generally speaking and on an electrical and electronical level, the system consists of the following elements:

* **Control circuit.**

- Tension stabilization.
- Analog-digital conversion.
- Oscillator.
- Output circuit.

* **Connections.**

- External connection.
- Connection potentiometer.

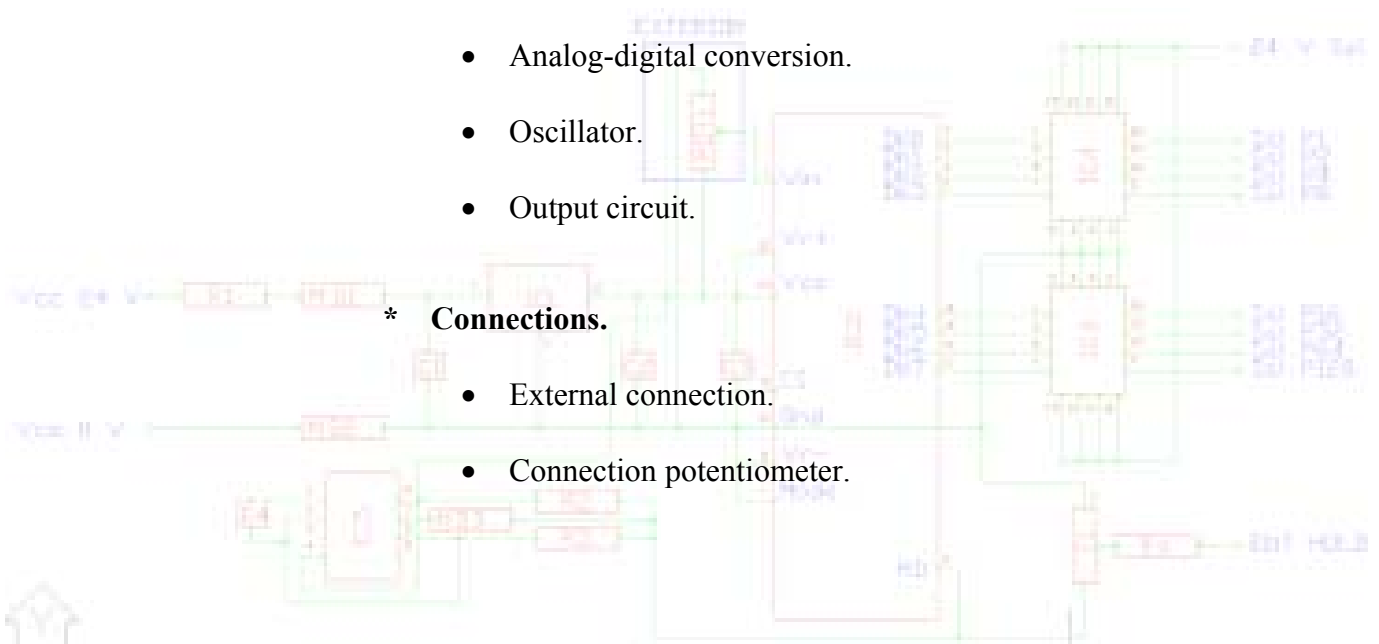

3.1. CONTROL CIRCUIT

It's the most important part of the system in charge of calculating the upper rim of the robot's electrode, informing it through the digital interface of the calculated value.

In order to do so, the circuit has been designed in the following way:

3.1.1. POWER STABILIZING

It disposes of a system for correction and filtering of the incoming signal that allows for a great variety in power currents.

3.1.2. DIGITAL CONVERSION

It's mission is to translate the position of the measuring system to a binary value which can be handled by the robot.

It is also in charge of memorizing the value shown at the moment of receiving the frozen measuring input.

3.1.3. OSCILLATOR

Adjusts the oscillation speed of the outputs given to the robot.

3.1.4. OUTPUT CIRCUIT

The circuit is connected with the robot's input card, incorporating a digital output system, free of potential.

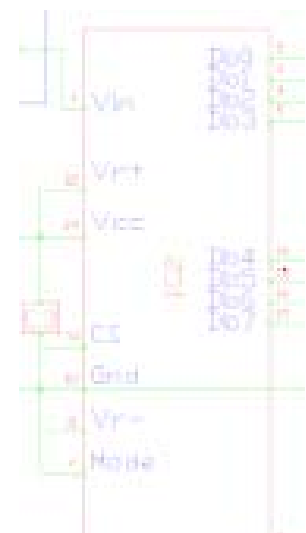

3.2. CONNECTIONS

The electronical system has been designed for swift change, without possibility of connection mistakes nor requiring diagrams or expertise, due to the introduction in the design of last generation connectors.

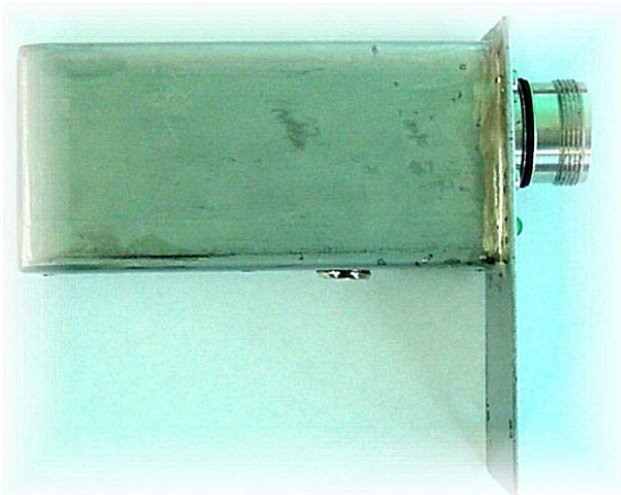

Linear Potentiometer



The system has a last generation linear potentiometer.

4.- MECHANICAL COMPOSITION

The mechanical system consists of the following elements:

1. PROTECTIVE COVER
2. SUPPORTING PANEL
3. SHEET SUPPORT
4. SPRING
5. UPPER SUPPORT..
6. CALYPER
7. COVER
8. BRACKET POTENTIOMETER
9. GUIDING SYSTEM.

